

THIS DRAWING IS UNPUBLISHED. RELEASED FOR PUBLICATION
 © COPYRIGHT - By - ALL RIGHTS RESERVED.

LOC	DIST	REVISIONS			
P	LTR	DESCRIPTION	DATE	DWN	APVD
AF	50	G	REVISED PER ECR-13-005733	23AUG2013	KH PD

- 1 CONTINUOUS STRIP ON REELS.
- 2 ACCEPTS WIRE SIZE [#16-#12 OR TWO #16'S].
- 3 INSULATION RANGE TO BE 4.06-5.33 [.160-.210] OR TWO 3.30 [.130] MAX DIA.
- 4 MATING TAB THK IS 0.81±0.025 [.032±.001].
- △5 INTERLEAVING PAPER REQUIRED.
- △6 PRELIMINARY - NOT FOR PRODUCTION

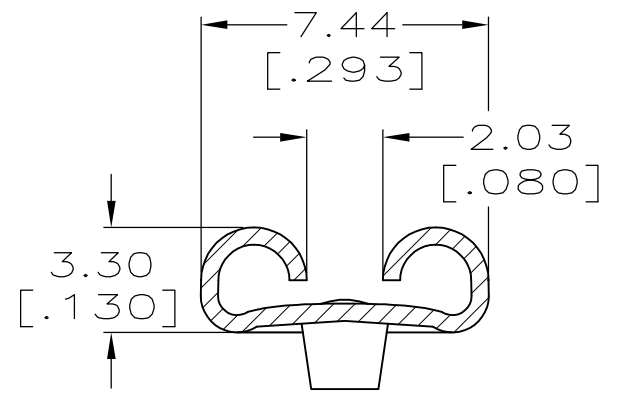
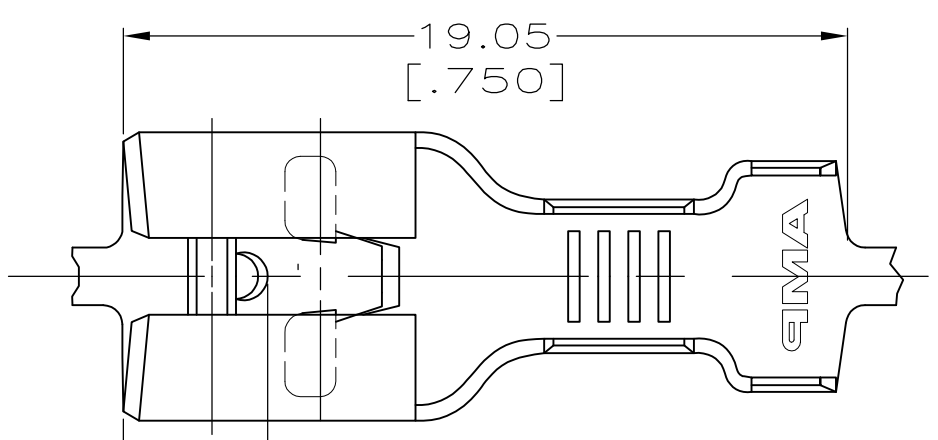

SECTION A-A

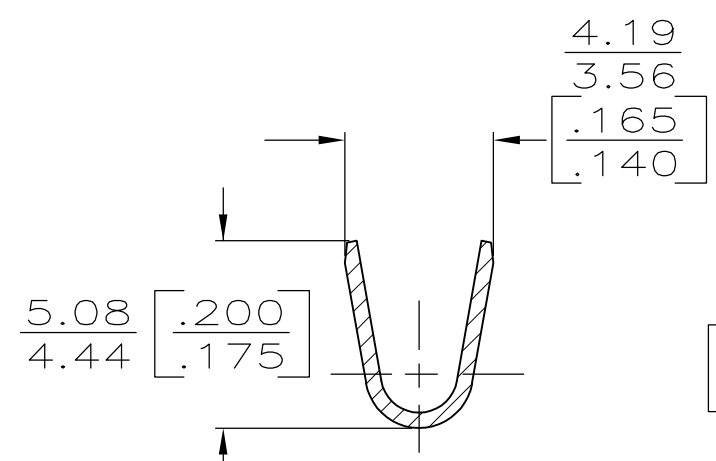
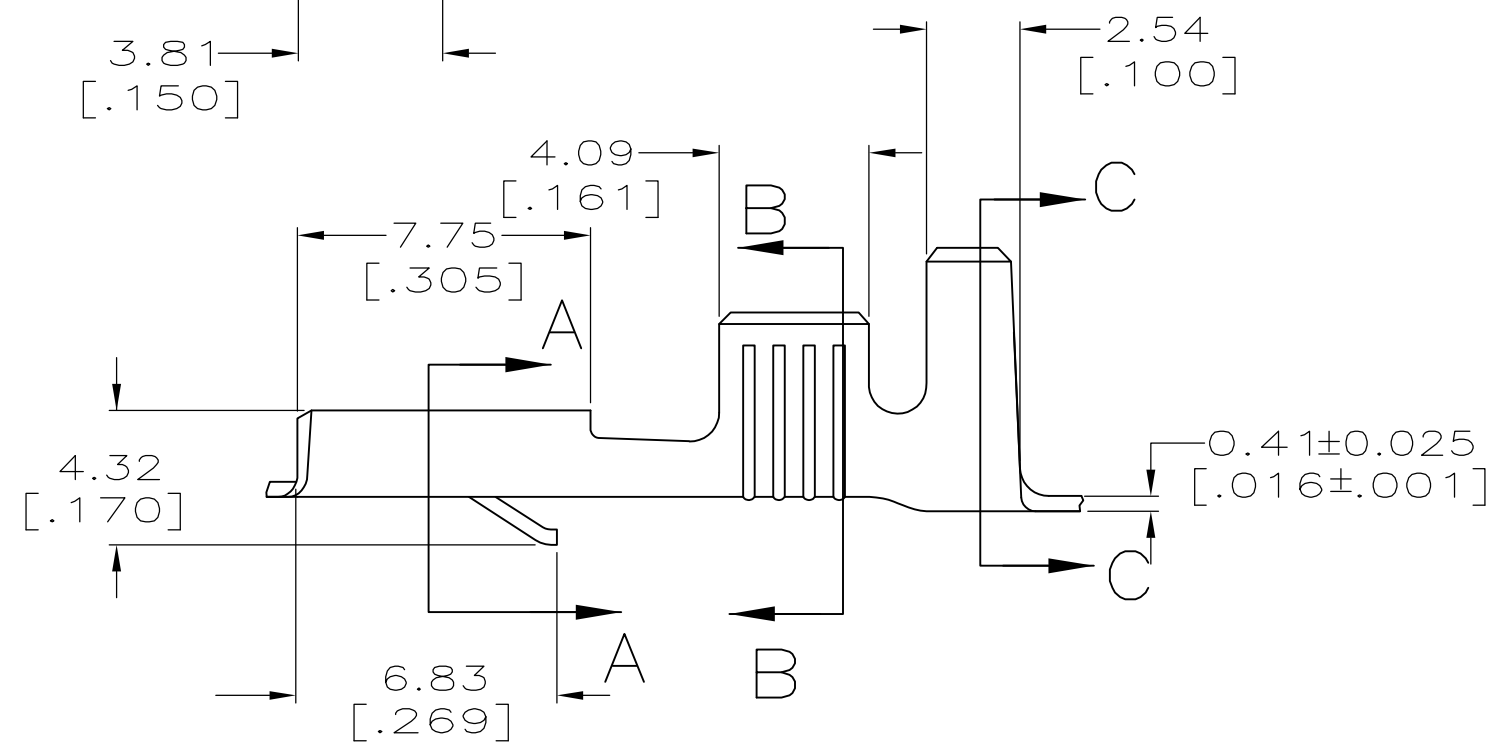

SECTION B-B

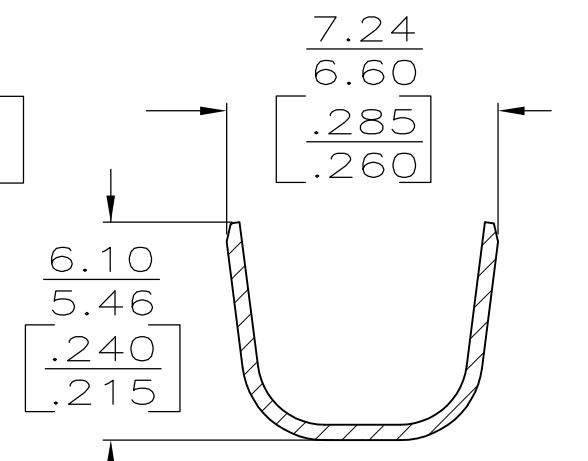

SECTION C-C

△5	0.002032 [.000080] MIN TIN	△6	60249-5
	0.000381 [.000015] THK SILVER		60249-3
	TIN		60249-2
	-		60249-1
	FINISH		PART NO

THIS DRAWING IS A CONTROLLED DOCUMENT.		DWN	JR RUTH	7/14/95	STE TE Connectivity		
DIMENSIONS: INCHES		CHK	MS FEHER	7/14/95			
TOLERANCES UNLESS OTHERWISE SPECIFIED:		APVD	J GILLESPIE	7/14/95	NAME		
0 PLC ± -		PRODUCT SPEC		RECEPTACLE, FASTIN-FASTON, 6.35 [.250] SERIES			
1 PLC ± -		APPLICATION SPEC		SIZE			
2 PLC ± 0.38 [.015]		114-2025		CAGE CODE			
3 PLC ± -		WEIGHT		DRAWING NO			
4 PLC ± -		-		A300779			
ANGLES ± -		CUSTOMER DRAWING		G-60249			
FINISH		SEE TABLE		RESTRICTED TO			
BRASS		SCALE		SHEET			
		5:1		1 OF 1			
		REV		G			